



Clifton Cameras Product Specification

Blackmagic URSA Broadcast G2

Specifications

Camera Features

Effective Sensor Size	2/3 inch sensor size when using 4K B4 mount (Actual sensor size 23.10mm x 12.99mm)
Lens Mount	B4 2/3 inch installed Active EF mount also included
Lens Control	Electronic control via 12-pin broadcast connector. Control via EF mount pins when using URSA Mini Pro EF Mount with compatible EF lenses.
Lens Correction	In-camera correction of color fringing when using compatible broadcast lenses.
Dynamic Range	13 Stops
Dual Native ISO	0dB and 18dB gain.
Sensitivity at 0dB Gain	f11 with 2160p59.94. f12 with 2160p50. at 2,000 lux with 89.9% reflectance. additional 1.1 stop light loss using 4K B4 mount.
Signal to Noise Ratio	64.62dB for 2160p Ultra HD scaled from 5.3K
Built in ND Filters	Four position ND filter wheel with clear, 2 stop, 4 stop and 6 stop ND filters.
Focus	Focus button triggers auto focus when using compatible lenses with focus servo. Touch and hold on LCD determines focus region and triggers auto focus.
Iris Control	Iris wheel and touchscreen slider for manual iris adjustment on electronically controllable lenses, iris button for instant auto iris settings on compatible lenses so no pixel is clipped in film mode. Scene average auto exposure in video and extended video mode.
Screen Dimensions	4 inch
Screen Type	LCD capacitive touchscreen.
Controls	Touchscreen menus on 4 inch screen. Push buttons for other controls. 3 assignable shortcut keys and 2 assignable shortcut keys (VTR and RET) on compatible broadcast lenses.



ProRes Shooting Resolutions and Frame Rates

3840 x 2160 (Ultra HD) up to 60 fps from Ultra HD window or scaled from 5.3K windowed sensor

3840 x 2160 (Ultra HD) up to 50 fps scaled from full sensor

1920 x 1080 (HD) up to 120 fps scaled from 2.7K windowed sensor

1920 x 1080 (HD) up to 60 fps scaled from Ultra HD or 5.3K windowed sensor

1920 x 1080 (HD) up to 50 fps scaled from full sensor

H.265 Shooting Resolutions and Frame Rates

3840 x 2160 (Ultra HD) up to 60 fps from Ultra HD window or scaled from 5.3K windowed sensor

3840 x 2160 (Ultra HD) up to 50 fps scaled from full sensor

H.264 Shooting Resolutions and Frame Rates

1920 x 1080 (HD) up to 60 fps scaled from Ultra HD or 5.3K windowed sensor

1920 x 1080 (HD) up to 50 fps scaled from full sensor

Blackmagic RAW Shooting Resolutions and Frame Rates

6144 x 3456 (6K) up to 50 fps

6144 x 2560 (6K 2.4:1) up to 60 fps

5376 x 3024 (5.3K 16:9) up to 60 fps

3728 x 3104 (3.7K 6:5 anamorphic) up to 60 fps

3840 x 2160 (Ultra HD) up to 60 fps

1920 x 1080 (HD) up to 150 fps

Project Frame Rates

23.98, 24, 25, 29.97, 30, 50, 59.94 and 60 fps.

Off-speed frame rates up to 60p in Ultra HD and up to 150p in HD.

Metadata Support

Automatically populated lens data from electronic B4 lenses. Automatic recording of camera settings and slate data such as project, scene number, take and special notes.

Timecode Clock

Highly accurate timecode clock. Less than 1 frame drift every 8 hours.



Connections

SDI Video Inputs	1
SDI Video Outputs	1
SDI Monitor Outputs	1
SDI Rates	1.5G, 3G, 6G, 12G.
Analog Audio Inputs	2 x XLR switchable between mic, line and AES digital audio. Phantom power support.
Analog Audio Outputs	1 x 3.5mm headphone jack, supports iPhone style headset for talkback.
Reference Inputs	Tri-Sync/Black Burst/Timecode.
Lens Control	1 x 12-pin Hirose Broadcast Lens Connector
Remote Control	1 x 2.5mm LANC input for Rec Start/Stop, plus Iris and Focus control using compatible lenses.
Computer Interface	1 x USB Type-C 3.1 Gen 2 with power delivery for external drive recording and connecting Blackmagic Focus and Zoom Demand. 1 x USB Type-C for software updates.

For diagrams of connections see below:

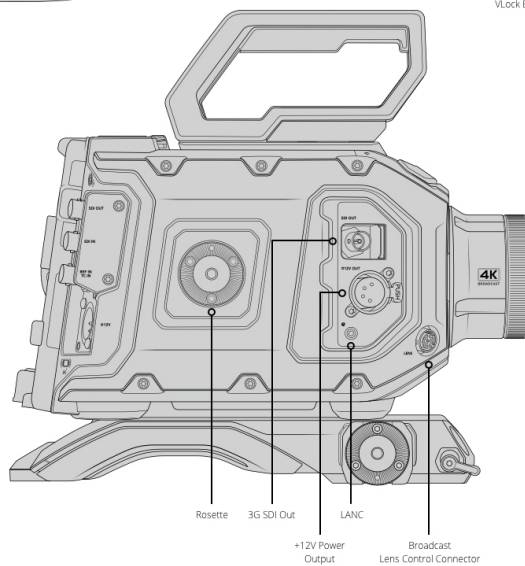
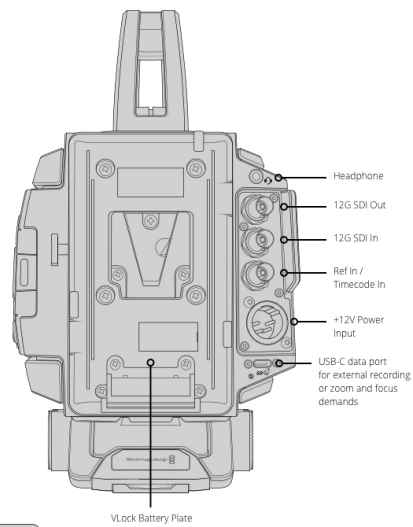
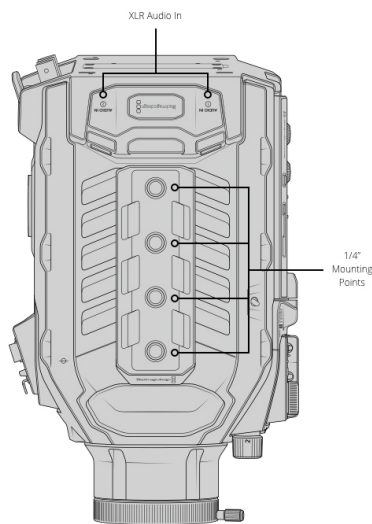
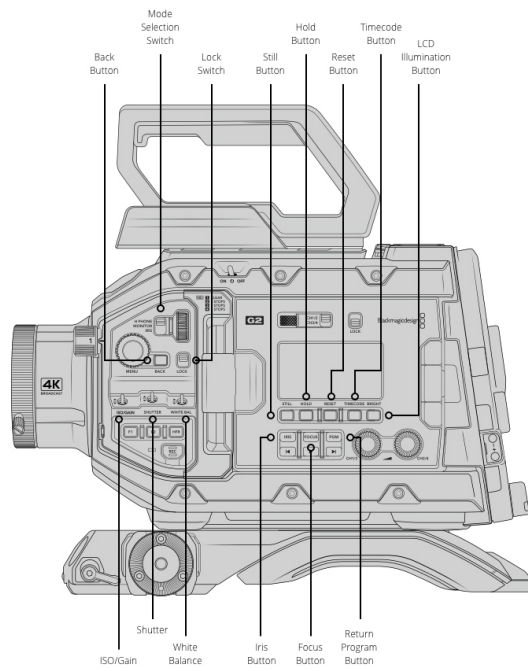
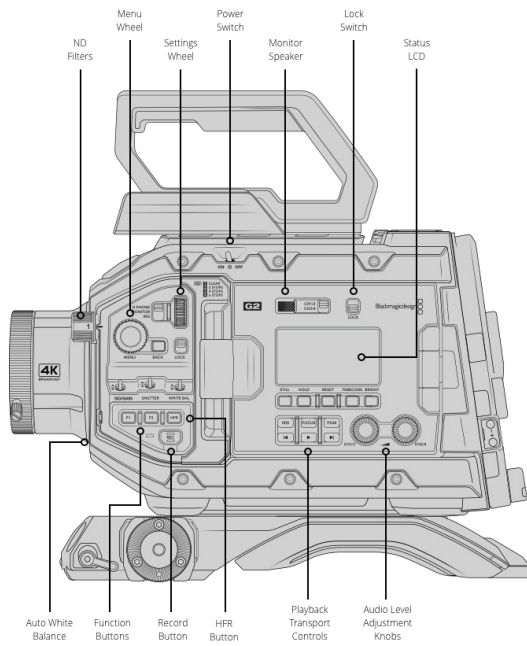



Audio

Microphone Integrated stereo microphone.

Built in Speaker 1 x mono speaker.

Standards

SD Video Standards None

HD Video Standards 1080p23.98, 1080p24, 1080p25, 1080p29.97, 1080p30, 1080p50, 1080p59.94, 1080p60 1080i50, 1080i59.94, 1080i60.

Ultra HD Video Standards 2160p23.98, 2160p24, 2160p25, 2160p29.97, 2160p30, 2160p50, 2160p59.94, 2160p60.

SDI Compliance SMPTE 292M, SMPTE 424M, SMPTE 425M level A and B, SMPTE 2081-1, SMPTE 2081-10, SMPTE 2082-1 and SMPTE 2082-10

SDI Audio Sampling 48 kHz and 24 bit

Media

Media 2 x CFast 2.0 card slots, 2 x SD UHS-II card slots, 1 x USB-C 3.1 Gen 2 expansion port with power delivery for recording to external media.

Media Format Can format media to ExFAT for Windows and Mac or HFS+ for Mac (file systems).

Supported Codecs

Apple ProRes 422 HQ,

Apple ProRes 422,

H.265 SDI (10-bit 4:2:2),

H.265 High (10-bit 4:2:0),

H.265 Medium (10-bit 4:2:0),

H.265 Low (10-bit 4:2:0),

H.264 SDI (10-bit 4:2:2),

H.264 High (8-bit 4:2:0),

H.264 Medium (8-bit 4:2:0),

H.264 Low (8-bit 4:2:0),

Blackmagic RAW Constant Bitrate 3:1,

Blackmagic RAW Constant Bitrate 5:1,



Blackmagic RAW Constant Bitrate 8:1,

Blackmagic RAW Constant Bitrate 12:1,

Blackmagic RAW Constant Quality Q0,

Blackmagic RAW Constant Quality Q1,

Blackmagic RAW Constant Quality Q3,

Blackmagic RAW Constant Quality Q5

Control

External Control Lens control of compatible lenses using Blackmagic Zoom Demand and Blackmagic Focus Demand, Blackmagic SDI Control Protocol, iPad control via Bluetooth, 1 x 2.5mm LANC for lens and record control.

Color Corrector

Color Corrector DaVinci YRGB.

Talkback and Tally

Talkback SDI Channels 15/16 and iPhone headset.

Live Tally Indicator Tally on LCD, URSA Viewfinder and URSA Studio Viewfinder.

Storage Features

Storage Type 2 x CFast 2.0
 2 x SD UHS-II cards
 1 x high speed USB-C expansion port for external media.
 2.5 inch SSD using optional URSA Mini Recorder

Storage Rates Storage rates based on 30 frames per second.

6144 x 3456 (6K)

Blackmagic RAW 3:1 - 323 MB/s

Blackmagic RAW 5:1 - 194 MB/s

Blackmagic RAW 8:1 - 121 MB/s

Blackmagic RAW 12:1 - 81 MB/s

Blackmagic RAW Q0 - 242 to 483 MB/s

Blackmagic RAW Q1 - 162 to 387 MB/s

Blackmagic RAW Q3 - 108 to 277 MB/s



Blackmagic RAW Q5 - 65 to 162 MB/s

6144 x 2560 (6K 2.4:1)

Blackmagic RAW 3:1 - 240 MB/s

Blackmagic RAW 5:1 - 144 MB/s

Blackmagic RAW 8:1 - 90 MB/s

Blackmagic RAW 12:1 - 60 MB/s

Blackmagic RAW Q0 - 180 to 359 MB/s

Blackmagic RAW Q1 - 120 to 287 MB/s

Blackmagic RAW Q3 - 80 to 205 MB/s

Blackmagic RAW Q5 - 49 to 120 MB/s

5376 x 3024 (5.3K 16:9)

Blackmagic RAW 3:1 - 248 MB/s

Blackmagic RAW 5:1 - 149 MB/s

Blackmagic RAW 8:1 - 94 MB/s

Blackmagic RAW 12:1 - 63 MB/s

Blackmagic RAW Q0 - 186 to 371 MB/s

Blackmagic RAW Q1 - 125 to 297 MB/s

Blackmagic RAW Q3 - 84 to 213 MB/s

Blackmagic RAW Q5 - 51 to 125 MB/s

3728 x 3104 (3.7K 6:5 anamorphic)

Blackmagic RAW 3:1 - 177 MB/s

Blackmagic RAW 5:1 - 106 MB/s

Blackmagic RAW 8:1 - 67 MB/s

Blackmagic RAW 12:1 - 45 MB/s

Blackmagic RAW Q0 - 133 to 265 MB/s

Blackmagic RAW Q1 - 89 to 212 MB/s

Blackmagic RAW Q3 - 60 to 152 MB/s

Blackmagic RAW Q5 - 36 to 89 MB/s



3840 x 2160 (Ultra HD)

Apple ProRes 422 HQ - 110 MB/s

Apple ProRes 422 - 73.6 MB/s

H.265 SDI - 12.3 MB/s

H.265 High - 10.8 MB/s

H.265 Medium - 7.8 MB/s

H.265 Low - 3.2 MB/s

Blackmagic RAW 3:1 - 127 MB/s

Blackmagic RAW 5:1 - 77 MB/s

Blackmagic RAW 8:1 - 48 MB/s

Blackmagic RAW 12:1 - 32 MB/s

Blackmagic RAW Q0 - 96 to 190 MB/s

Blackmagic RAW Q1 - 64 to 153 MB/s

Blackmagic RAW Q3 - 43 to 109 MB/s

Blackmagic RAW Q5 - 26 to 64 MB/s

1920 x 1080

Apple ProRes 422 HQ - 27.5 MB/s

Apple ProRes 422 - 18.4 MB/s

H.264 SDI - 7.0 MB/s

H.264 High - 5.6 MB/s

H.264 Medium - 3.2 MB/s

H.264 Low - 1.8 MB/s

Blackmagic RAW 3:1 - 19 MB/s

Blackmagic RAW 5:1 - 12 MB/s

Blackmagic RAW 8:1 - 7.8 MB/s

Blackmagic RAW 12:1 - 5.2 MB/s

Blackmagic RAW Q0 - 23 to 47 MB/s

Blackmagic RAW Q1 - 16 to 37 MB/s

Blackmagic RAW Q3 - 10 to 27 MB/s



Blackmagic RAW Q5 - 6 to 16 MB/s

*Constant Quality storage rates quoted are indicative only. Actual storage rates are entirely dependent on image subject matter.

Recording Formats

Apple ProRes 3840 x 2160 and 1920 x 1080 with film, video or extended video dynamic range or custom 3D LUT.

H.265 3840 x 2160 with film, video or extended video dynamic range or custom 3D LUT.

H.264 1920 x 1080 with film, video or extended video dynamic range or custom 3D LUT.

Blackmagic RAW Q0, Q1, Q3, Q5, 3:1, 5:1, 8:1 and 12:1 at 6144 x 3456, 6144 x 2560, 5376 x 3024, 3728 x 3104, 3840 x 2160, 1920 x 1080 recorded in non-linear 12 bit with film dynamic range and extended video, video or custom 3D LUT embedded in metadata.

Software

Software Included

Blackmagic OS

DaVinci Resolve Studio for Mac and Windows including activation key

Blackmagic Camera Setup

Blackmagic RAW Player

Blackmagic RAW QuickLook Plugin

Blackmagic RAW SDK

Blackmagic RAW Speed Test